

EmETX-a55E0

ETX® CPU Module Quick Installation Guide

Version 1.1

Form Factor
<i>ETX® CPU Module</i>

CPU
<i>Soldered onboard AMD G-Fusion G-T56N 1.65GHz Processor</i>

Chipset
<i>AMD FCH A55E</i>

Video
<i>Dual Channels 24-bit LVDS, Analog RGB, DDI port</i>

Audio
<i>Realtek HD AUDIO CODEC, Mic-in/ Line-in/ Line-out</i>

I/O
<i>PCI/ ISA/ SATA/ USB IDE/ COM/ LPT</i>

LAN
<i>Realtek RTL8105E 10/100 Base-T Ethernet</i>

◆ Technical Support

If you have any technical difficulties, please consult the user's manual first at:
<http://www.arbor.com.tw>

Please do not hesitate to call or e-mail our customer service when you still can not find out the answer.

<http://www.arbor.com.tw>

E-mail: info@arbor.com.tw

FCC Class A

This device complies with Part 15 of the FCC Rules. Operation is subject to the following two conditions : (1) this device may not cause harmful interference, and (2) this device must accept any interference received, including interference that may cause undesired operation.

Copyright® All Rights Reserved.

4041550000110P



Packing List

Before you begin installing your single board, please make sure that the following materials have been shipped:



1 x EmETX-a55E0 ETX® CPU Module



1 x Driver CD
1 x Quick Installation Guide

Ordering Information

EmETX-a55E0-T56N	AMD G-Fusion G-T56N 1.65GHz ETX® CPU Module
HS-55E0-F1	Heat spreader
HS-55E0-C1	CPU module cooler for 18W APU (114*95*29mm)
PBE-1000 R2.1	ETX® evaluation board in ATX form factor
CBK-05-1000-00	Cable kit for PBE-1000 R2.1 2 x IDE cables 3 x COM port cables 1 x USB cable

The Installation Paths of CD Driver

Windows XP

Driver	Path
CHIPSET & VGA	\\EmETX-a55E0\GRAPHICS\XP\8.92-111109a-129010C-EDG_Direct
LAN	\\EmETX-a55E0\ETHERNET\WinXP\PCIE_Install_5792_01142012
AUDIO	\\EmETX-a55E0\AUDIO\WinXP\WDM_R267

Windows 7

Driver	Path
CHIPSET & VGA	\\EmETX-a55E0\GRAPHICS\Win7\8.92-111109a-129011C-EDG_Direct
LAN	\\EmETX-a55E0\ETHERNET\win7\Install_Win7_7050_01162012
AUDIO	\\EmETX-a55E0\AUDIO\Win7\Vista_Win7_R267

Specifications

Form Factor	ETX® CPU Module
CPU	Soldered onboard AMD G-Fusion G-T56N 1.65GHz Processor
Chipset	AMD FCH A55E
System Memory	1 x 204-pin DDR3 SO-DIMM Socket up to 4GB 1333MHz SDRAM
VGA/ LCD Controller	Integrated Radeon HD 6320 with Analog RGB/ 24-bit dual channels LVDS (Dual independent displays)
Ethernet	1 x Realtek RTL8105E 10/100 Base-T Ethernet
Audio	Realtek ALC886 7.1 Channel HD Audio Codec, support Mic-in/Line-in/Line-out
BIOS	AMI PnP Flash UEFI BIOS
Serial ATA	2 x Serial ATA with 600MB/s HDD transfer rate
IDE Interface	2 x Ultra ATA, support 4 IDE devices
Serial Port	2 x COM Ports (1 x RS-232, 1 x RS-232/422/485 selectable via PBE-1000)
Parallel Port	1 x SPP/EPP/ECP mode
KB/MS	Support PS/2 interface Keyboard and Mouse
Universal Serial Bus	4 x USB 2.0 ports
LCD	Dual Channels 24-bit LVDS
DDI output	Supports extra DisplayPort
Expansion Interface	4 x PCI masters and ISA Bus LPC interface DDI port connector on CPU module
Operation Temp.	-20°C ~ 70°C (-4°F~158°F)
Watchdog Timer	1~255 level Reset
Dimension (L x W)	114 x 95 mm (4.5" x 3.7")

Board Layout Top View

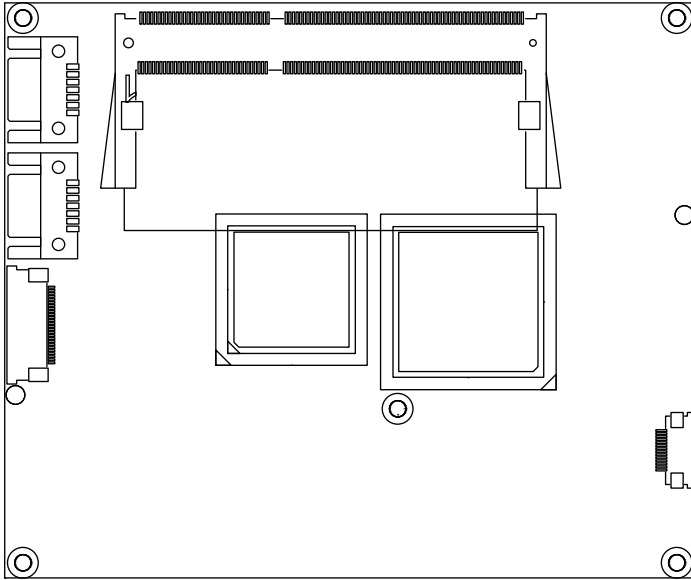

Board Layout Bottom View



Board Dimensions

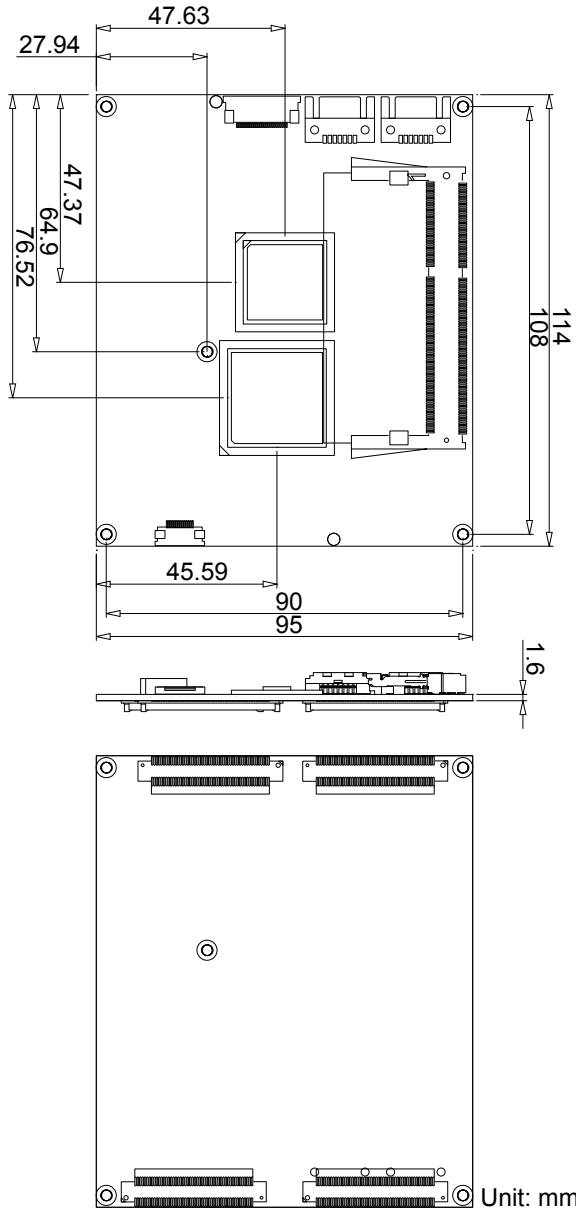

SATA1, SATA2 Connectors

Pin	Description
1	GND
2	TX+
3	TX-
4	GND
5	RX-
6	RX+
7	GND

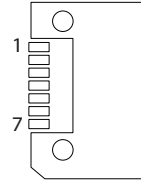

LPC1 Connector

Connector type: FPC12-14P-P0.5 (Hirose)

Pin	Description	Pin	Description
1	LAD0	8	BUF_PLT_RST#
2	LAD1	9	GND
3	LAD2	10	PCLK_CONN
4	LAD3	11	GND
5	GND	12	GND
6	LFRAME#	13	+3.3V
7	INT_SERIRQ	14	+3.3V

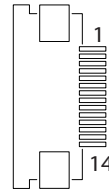

DDI1 Connector

Connector type: FH12-26S-0.5SH (Hirose)

Pin	Description	Pin	Description
1	GND	14	N/C
2	DDI_TX0+	15	DDI_AUX+
3	DDI_TX0-	16	DDI_AUX-
4	GND	17	GND
5	DDI_TX1+	18	DDI_HPDP
6	DDI_TX1-	19	SMB_DAT
7	GND	20	SMB_CLK
8	DDI_TX2+	21	GND
9	DDI_TX2-	22	GND
10	GND	23	GND
11	DDI_TX3+	24	+3.3V
12	DDI_TX3-	25	+3.3V
13	GND	26	+5V

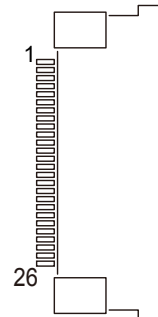

ETX1 Connector

A1	GND	GND	A2
A3	PCICLK3	PCICLK4	A4
A5	GND	GND	A6
A7	PCICLK1	PCICLK2	A8
A9	REQ#3	GNT#3	A10
A11	GNT#2	VCC3	A12
A13	REQ#2	GNT#1	A14
A15	REQ#1	VCC3	A16
A17	GNT#0	N.C	A18
A19	VCC	VCC	A20
A21	SERIRQ	REQ#0	A22
A23	AD0	VCC3	A24
A25	AD1	AD2	A26
A27	AD4	AD3	A28
A29	AD6	AD5	A30
A31	CBE#0	AD7	A32
A33	AD8	AD9	A34
A35	GND	GND	A36
A37	AD10	AUXAL	A38
A39	AD11	MIC	A40
A41	AD12	AUXAR	A42
A43	AD13	ASVCC	A44
A45	AD14	SNDL	A46
A47	AD15	ASGND	A48
A49	CBE#1	SNDR	A50
A51	VCC	VCC	A52
A53	PAR	SERR#	A54
A55	PERR#	N.C	A56
A57	PME#	USB2-	A58
A59	LOCK#	DEVSEL#	A60
A61	TRDY#	USB3-	A62
A63	IRDY#	STOP#	A64
A65	FRAME#	USB2+	A66
A67	GND	GND	A68
A69	AD16	CBE#2	A70
A71	AD17	USB3+	A72
A73	AD19	AD18	A74
A75	AD20	USB0-	A76
A77	AD22	AD21	A78
A79	AD23	USB1-	A80
A81	AD24	CBE#3	A82
A83	VCC	VCC	A84
A85	AD25	AD26	A86
A87	AD28	USB0+	A88
A89	AD27	AD29	A90
A91	AD30	USB1+	A92
A93	PCIRST#	AD31	A94
A95	INTR#C	INTR#D	A96
A97	INTR#A	INTR#B	A98
A99	GND	GND	A100

ETX2 Connector

B1	GND	GND	B2
B3	SD14	SD15	B4
B5	SD13	MASTER#	B6
B7	SD12	DREQ7	B8
B9	SD11	DACK#7	B10
B11	SD10	DREQ6	B12
B13	SD9	DACK#6	B14
B15	SD8	DREQ5	B16
B17	MEMW#	DACK#5	B18
B19	MEMR#	DREQ0	B20
B21	LA17	DACK#5	B22
B23	LA18	IRQ14	B24
B25	LA19	IRQ15	B26
B27	LA20	IRQ12	B28
B29	LA21	IRQ11	B30
B31	LA22	IRQ10	B32
B33	LA23	IO16#	B34
B35	GND	GND	B36
B37	SBHE#	M16#	B38
B39	SA0	OSC	B40
B41	SA1	BALE	B42
B43	SA2	TC	B44
B45	SA3	DACK#2	B46
B47	SA4	IRQ3	B48
B49	SA5	IRQ4	B50
B51	VCC	VCC	B52
B53	SA6	IRQ5	B54
B55	SA7	IRQ6	B56
B57	SA8	IRQ7	B58
B59	SA9	SYSCLK	B60
B61	SA10	REFCH#	B62
B63	SA11	DREQ1	B64
B65	SA12	DACK#1	B66
B67	GND	GND	B68
B69	SA13	DREQ3	B70
B71	SA14	DACK#3	B72
B73	SA15	IOR#	B74
B75	SA16	IOW#	B76
B77	SA18	SA17	B78
B79	SA19	SMEMR#	B80
B81	IOCHRDY	AEN	B82
B83	VCC	VCC	B84
B85	SD0	SMEMW#	B86
B87	SD2	SD1	B88
B89	SD3	NEWS#	B90
B91	DREQ2	SD4	B92
B93	SD5	IRQ9	B94
B95	SD9	SD7	B96
B97	IOCHK#	RSTDRV	B98
B99	GND	GND	B100

ETX3 Connector

C1	GND		GND	C2
C3	R		B	C4
C5	HSY		G	C6
C7	VSY	Analog RGB_DDC_CLK		C8
C9	DETECT#	Analog RGB_DDC_ATA		C10
C11	TX2CLK#		N.C.	C12
C13	TX2CLK		N.C.	C14
C15	GND		GND	C16
C17	TX2D1		TX2D2	C18
C19	TX2D1#		TX2D2#	C20
C21	GND		GND	C22
C23	N.C.		TX2D0	C24
C25	N.C.		TX2D0#	C26
C27	GND		GND	C28
C29	TX1D2#		TX1CLK	C30
C31	TX1D2		TX1CLK#	C32
C33	GND		GND	C34
C35	TX1D0		TX1D1	C36
C37	TX1D0#		TX1D1#	C38
C39	VCC		VCC	C40
C41	DDC_DATA		N.C.	C42
C43	DDC_CLK		BLON#	C44
C45	BKLTCTL		VDDEN	C46
C47	TV_DATA_COMP		Y	C48
C49	N.C.		C	C50
C51	LPT/FLPY#		N.C.	C52
C53	VCC		GND	C54
C55	STB#		AFD#/DENSEL	C56
C57	N.C.		PD7/N.C	C58
C59	IRR#		ERR#/HDSSEL#	C60
C61	IRTX		PD6/N.C	C62
C63	RXD2		INIT#/DIR#	C64
C65	GND		GND	C66
C67	RTS#2		PD5/N.C	C68
C69	DTR#2		SLIN#/STEP#	C70
C71	DCD#2		PD4/DSKCHG#	C72
C73	DSR#2		PD3/RDATA#	C74
C75	CTS#2		PD2/WP#	C76
C77	TXD#2		PD1/TRK0#	C78
C79	R#2		PDO/INDEX#	C80
C81	VCC		VCC	C82
C83	RXD1		ACK#/DRV	C84
C85	RTS#1		BUSY#/MOT	C86
C87	DTR#1		PE/WDATA#	C88
C89	DCD#1		SLCT#/WGATE#	C90
C91	DSR#1		MSCLK	C92
C93	CTS#1		MSDAT	C94
C95	TXD#1		KBCLK	C96
C97	R#1		KBDAT	C98
C99	GND		GND	C100

ETX4 Connector

D1	GND		GND	D2
D3	5V_SB		PWGIN	D4
D5	PS_ON		SPEAKER	D6
D7	PWERBTN#		BATT	D8
D9	KBINH		LILED	D10
D11	RSMRST#		ACTLED	D12
D13	N.C		SPEEDLED	D14
D15	N.C		I2CLK	D16
D17	VCC		VCC	D18
D19	OVC#		N.C	D20
D21	EXTSMI#		I2DAT	D22
D23	SMBCLK		SMBDAT	D24
D25	SIDE_CS1#		SMBALRT#	D26
D27	SIDE_CS0#		SATALED#	D28
D29	SIDE_A2		PIDE_CS#	D30
D31	SIDE_A0		PIDE_CS1#	D32
D33	GND		GND	D34
D35	PDIAG_S		PIDE_A2	D36
D37	SIDE_A1		PIDE_A0	D38
D39	SIDE_INTRQ		PIDE_A1	D40
D41	BATLOW#		N.C	D42
D43	SIDE_ACK#		PIDE_INTRQ	D44
D45	SIDE_RDY		PIDE_ACK#	D46
D47	SIDE_IOR#		PIDE_IOR#	D48
D49	VCC		VCC	D50
D51	SIDE_IOW#		PIDE_IOR#	D52
D53	SIDE_DRQ		PIDE_IOW#	D54
D55	SIDE_D15		PIDE_DRQ	D56
D57	SIDE_D0		PIDE_D15	D58
D59	SIDE_D14		PIDE_D0	D60
D61	SIDE_D1		PIDE_D14	D62
D63	SIDE_D13		PIDE_D1	D64
D65	GND		GND	D66
D67	SIDE_D2		PIDE_D13	D68
D69	SIDE_D12		PIDE_D2	D70
D71	SIDE_D3		PIDE_D12	D72
D73	SIDE_D11		PIDE_D3	D74
D75	SIDE_D4		PIDE_D11	D76
D77	SIDE_D10		PIDE_D4	D78
D79	SIDE_D5		PIDE_D10	D80
D81	VCC		VCC	D82
D83	SIDE_D9		PIDE_D5	D84
D85	SIDE_D6		PIDE_D9	D86
D87	SIDE_D8		PIDE_D6	D88
D89	GPE2#		CBLID_#	D90
D91	RXD-		PIDE_D8	D92
D93	RXD+		N.C	D94
D95	TXD-		PIDE_D7	D96
D97	TXD+		HDRST#	D98
D99	GND		GND	D100